

User Handbook

DISC SPRING STARTERS SS/HSS & SR/HSR Models



This page is left intentionally blank

Contents

Page No.

3	Introduction
3	Your Spring Starter
4	Assembling the Winding Handle
5	Pre-Installation Checks
8	Fitting the Spring Starter
9	Engine 'Walk Over' to Check Pinion Engagement
11	Starting for the First Time
12	Standard Starting Procedure
12	Unwinding the Spring Starter
13	E-Pack Installation Guide
14	Troubleshooting
15	Warranty Terms
16	General Terms & Conditions
18	Card Gauge

WARNING



Please ensure the warranty card supplied with the spring starter is filled out and returned to Kineteco. **Failure to do so will invalidate the warranty**

The spring starter must be installed and operated as described in this handbook. **Failure to do so will invalidate the warranty**

This page is left intentionally blank

1. Introduction

The following pages of this handbook should be worked through in sequence. This will ensure the spring starter is correctly set up for the engine it is to be fitted to, and the user will have a full understanding of the safe and reliable operation of the spring starter.

Allow **at least 30 minutes** to follow these instructions step-by-step to ensure correct operation.

If there are any queries about your spring starter that are not explained in the handbook, please get in touch with Kineteco via the contacts at the bottom of the page.

Once the handbook has been used to setup, install and operate the spring starter for the first time, please keep it in a safe place for future reference.

2. Your Spring Starter

Please take a moment to familiarise yourself with the features of the product shown in **Fig 1**. The instructions contained in this handbook will use these descriptions.

Fig 1

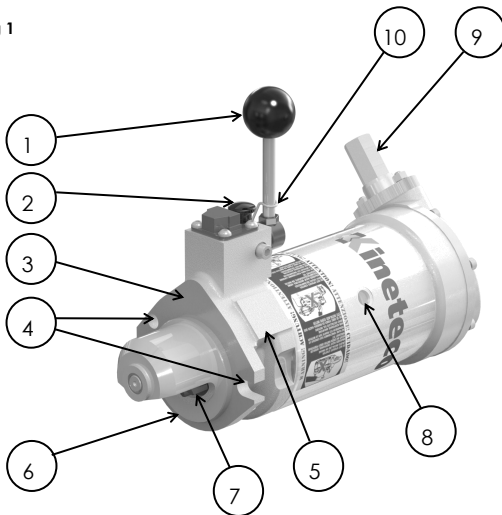

Number	Description
1	Trip lever
2	Release pin
3	Mounting flange
4	Mounting holes
5	Nosepiece
6	Spigot
7	Pinion gear
8	Inspection window
9	Winding adaptor
10	Torsion spring

(Exact configuration will vary)

3. Assembling the Winding Handle

Your spring starter comes supplied with a winding handle that needs to be assembled before use. Please follow instructions below:

- a. Fit male square drive of sleeve into crank handle as shown in **Fig 2i**
- b. Screw together with supplied M10 bolt, spring washer and plain washer in order shown in **Fig 2i**, tighten with 17mm spanner, to result in completed assembly as shown in **Fig 2ii**

Fig 2i

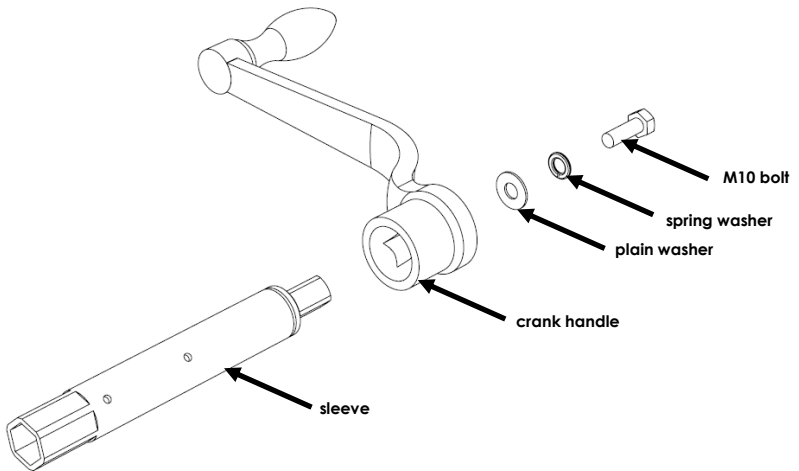
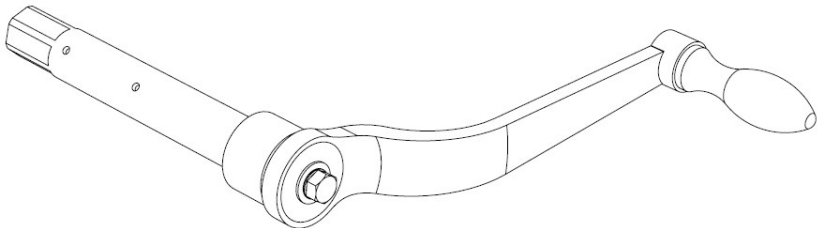

Fig 2ii



4. Pre-Installation Checks

Before installing or using the spring starter the following checks should be made.

These checks will determine whether the starter rotates in the correct direction for the engine it is to be fitted to; whether the pinion will have enough clearance from the engine's ring gear; and lastly whether the pinion engages correctly with the ring gear.

It is very important to make these checks before using the spring starter. If the starter is not correctly matched to the engine, the spring starter, engine, or both, could be damaged.

If at any stage of these checks the spring starter does not appear to be correct, please contact Kineteco immediately where our trained technical staff will be able to help with any issues.

- a. To check that the spring starter will rotate the engine in the correct direction, check the spring starter model number:
- An 'SS' starter pinion rotates clockwise viewed from pinion end
 - An 'SR' starter pinion rotates anti-clockwise viewed from pinion end

On an engine where the starter fits along the side of the engine block as per **Fig 3i**, an SS starter rotates the flywheel anti-clockwise viewed from the flywheel end. An SR starter rotates the flywheel clockwise viewed from the flywheel end

Fig 3i

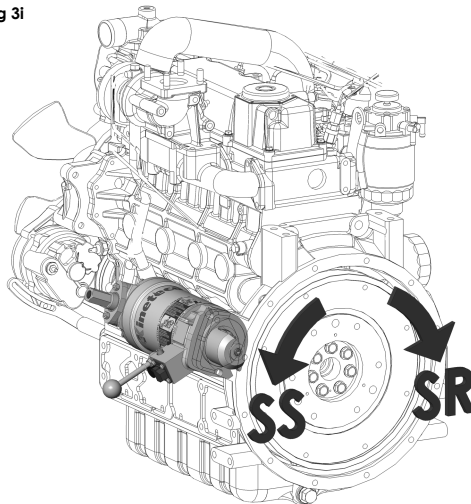

- b. Next, check the pinion's clearance from the ring gear. Cut out the card gauge from the back page of this handbook following the dashed lines
- c. Measure the 'flange to ring gear' dimension **A**, as shown in **Fig 3ii**

Fig 3ii

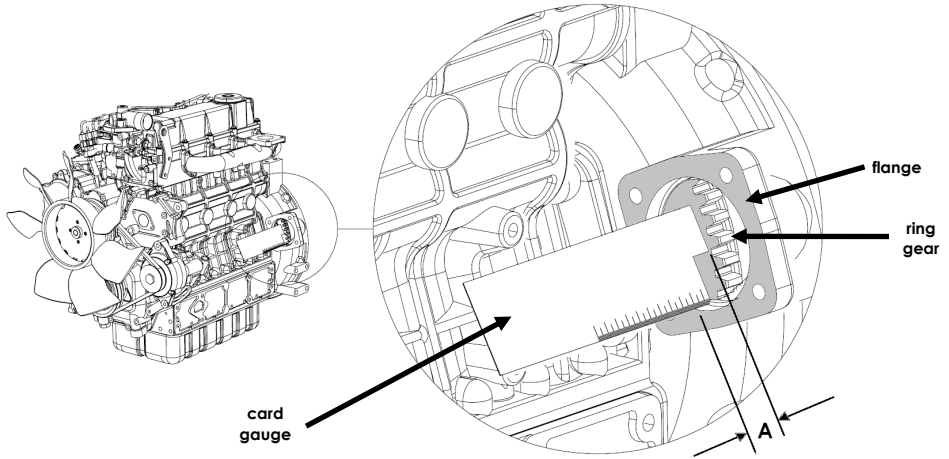

- d. Make sure the spring starter's pinion is as far back into the starter body as it can go, known as the 'pinion at rest' position
- e. Measure the 'pinion at rest' dimension **B**, as shown in **Fig 3iii**, making sure any spacers are fitted to the starter flange face if supplied with the spring starter

Fig 3iii

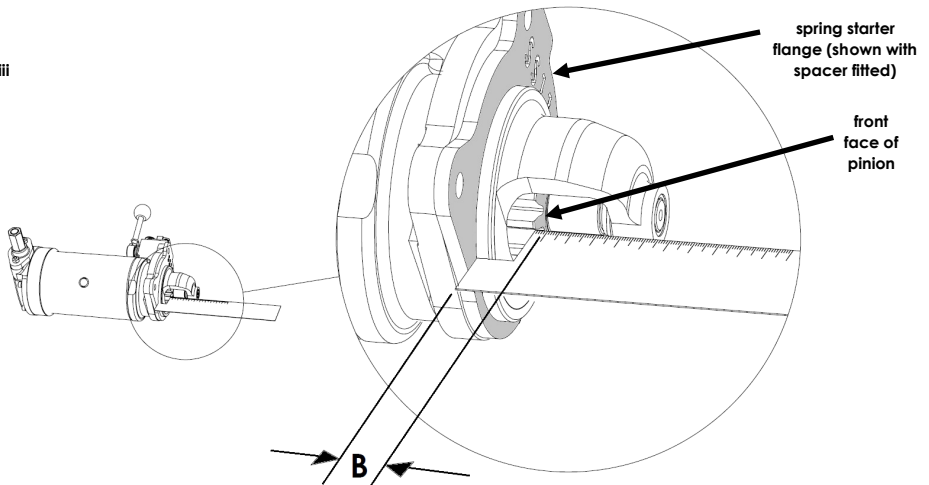

- f. Then, $A-B=C$, where **C** is the clearance between the pinion and ring gear. This should be between **3 to 5mm**

The last pre-installation check ensures the pinion will not hit the flywheel when fully extended. (This is only necessary on engines with a flywheel that has a shoulder of larger diameter than the root diameter of the ring gear.)

- g. Use the card gauge to measure from the front face of the ring gear to the shoulder of the flywheel, dimension **D**, as shown in **Fig 3iv**

Fig 3iv

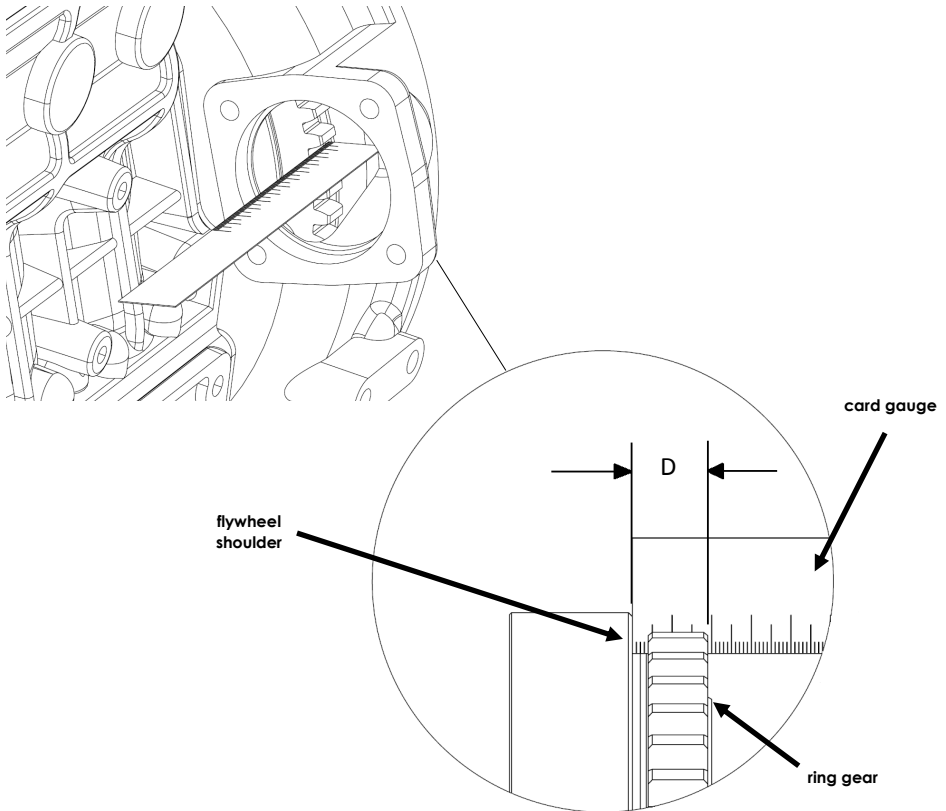

- h. Then, $C+D=E$, where **E** must be greater than 20mm, as this is the distance that the pinion will travel forward when engaged in the ring gear

5. Fitting the Spring Starter

The next steps check that the spring starter fits onto the engine. The starter will be mounted to the engine in this step but **DO NOT** attempt to start the engine. The starter will be removed from the engine after this step.

- a. Mount the spring starter into the pocket (not forgetting to include any spacers supplied with the spring starter) as shown in **Fig 4i** using existing studs and nuts torqued to the engine manufacturer's specifications. Kineteco do not supply these studs or nuts

Fig 4i

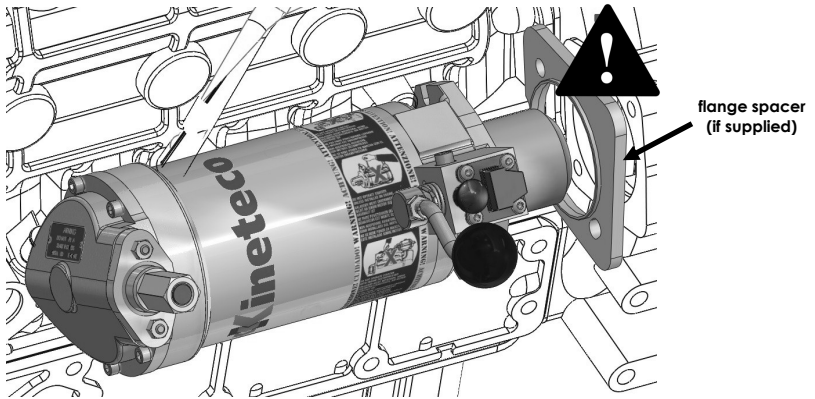

- b. Ensure the spring starter flange face sits flat on the mounting plate and is not jammed at an angle against the engine block, by passing a piece of paper between the spring starter and the engine block, **Fig 4ii**. **Fig 4iii** shows a correctly installed starter

Fig 4ii

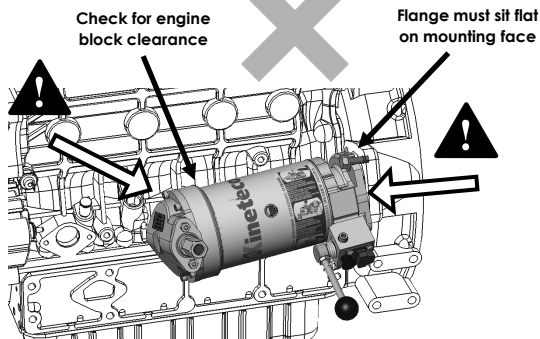
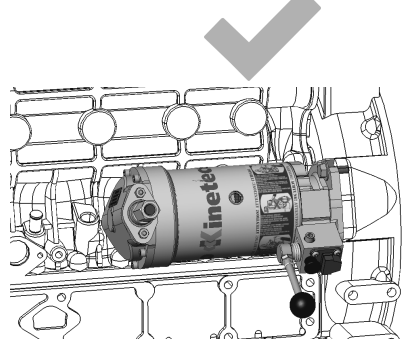

Fig 4iii



6. Engine 'Walk Over' to Check Pinion Engagement

This procedure ensures the pinion teeth engage correctly with the engine's ring gear so that starting will be smooth and excessive wear will not occur.

- a. Disconnect the battery negative lead, if electrical starting system is present, and ensure the engine is out of gear
- b. **RESET** the spring starter:
 1. Lift the release pin with one hand holding the trip lever with the other, **Fig 5i**
 2. Pull the trip lever up against the spring force, **Fig 5ii**
 3. Let go of release pin and the trip lever will click and lock in vertical position, **Fig 5iii**

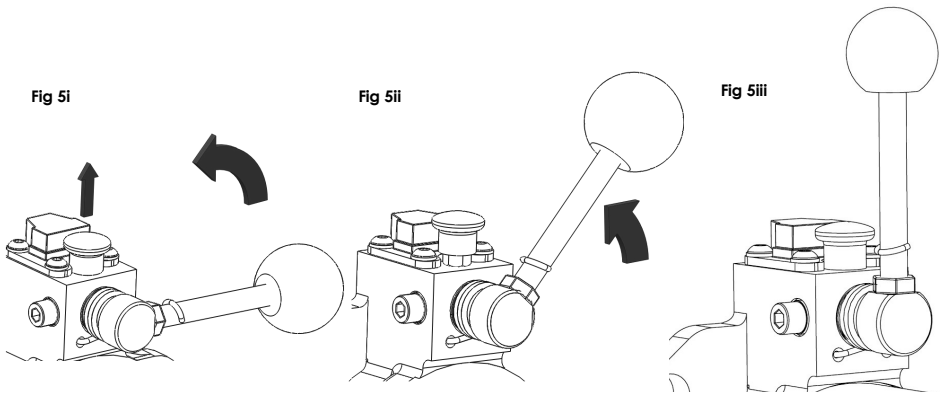

- c. Fit the winding handle onto the winding adaptor and wind **CLOCKWISE, Fig 5iv**. Stop winding as soon as an increase in winding load is detectable (approx. two turns). This will pre-engage the pinion into the engine's ring gear.

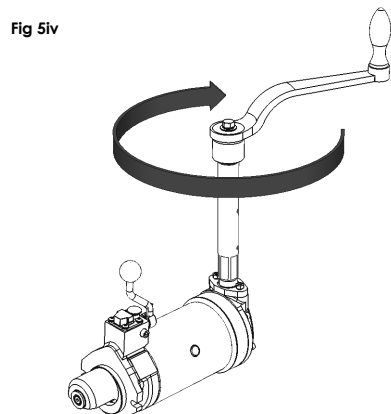

d. **TRIP** the spring starter:

- Grasp the trip lever in one hand and lift the release pin with the other, **Fig 5v**
- Push lever firmly across 90 degrees, **Fig 5vi**
- Let go of release pin and the trip lever will lock in horizontal position as shown, **Fig 5vii**

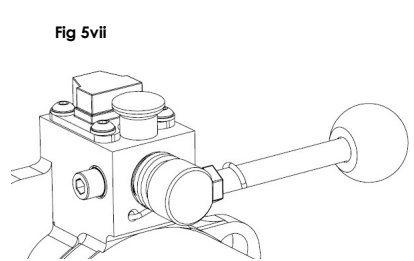
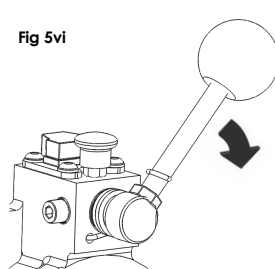
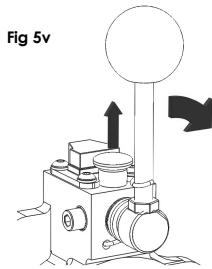

e. Continue winding the handle **CLOCKWISE**, which should now be turning the engine over

f. Ensure there are no tight spots in the pinion to ring gear mesh by making a complete revolution of the ring gear in this fashion

g. Disengage the pinion by unwinding the starter. This is done by winding the handle **ANTI-CLOCKWISE** for at least 3 turns, **Fig 5viii**. (An increase in effort will be needed to begin with. During unwinding no ratchet click will be heard)

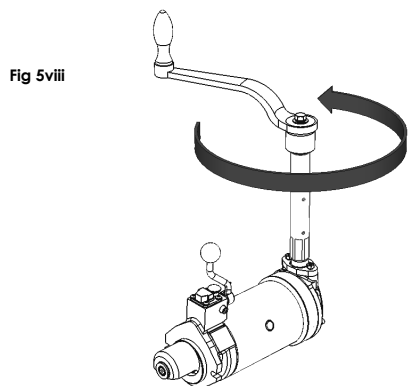

h. Dismount the spring starter from the engine and inspect the pinion teeth. Engagement is correct if witness/wear marks show across most of the driven surface of the gear tooth, **Fig 5ix**

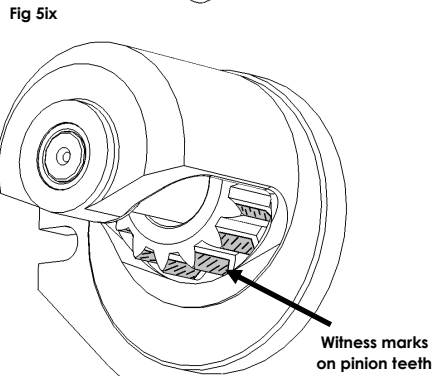

If the starter engages correctly, remount the starter and continue to the next section of this handbook. If all the instructions have been followed and the starter does not engage as specified, please contact Kineteco for further guidance.

7. Spring Starting for the First Time

The starter may now be operated but only under a minimal load for the initial operations. Starting under full charge can reduce the spring life and is not always necessary. Follow these steps the first time you attempt to start the engine with the spring starter

- a. Ensure all steps prior to this page in the handbook have been carried out thoroughly
- b. Ensure that the engine and machinery are safely prepared for starting, including taking vehicles out of gear and cylinders are **NOT** decompressed



WARNING

Do not use spring starter when engine is decompressed

- c. Check that the fuel tap is in the 'on' position, and that sufficient fuel is in the tank
- d. Position the throttle as per the engine manufacturer's instructions for starting. Most engines require at least a 3/4 open position
- e. **RESET** the spring starter
- f. Wind the starter **CLOCKWISE** five rotations of the handle. You should be able to hear the winding ratchet clicking while you do this, if not, keep winding until you do and then count rotations
- g. Remove the winding handle from the winding adaptor, **Fig 6**

Fig 6

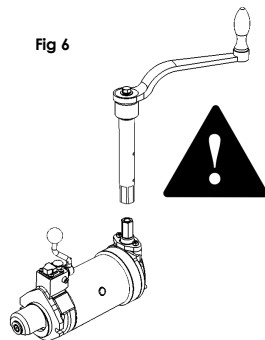

WARNING

Always remove the winding handle before tripping the starter

- h. Operate the engine's manual fuel lift pump (if fitted) to ensure good fuel supply to the engine
- i. **TRIP** the spring starter
- j. If the engine starts continue to step **k**. If not, wait for rotation to stop. Then return to step **e**, adding an extra handle rotation during winding. Continue to increase winding amount in this way by one rotation each trip until engine starts



WARNING

DO NOT ATTEMPT TO WIND FURTHER THAN RED SPRINGS

- k. When engine starts, adjust the throttle to the desired level
- l. Make a note of the number of winds made when the engine started and mark on the quick reference operator's instructions label as the 'advised number of winds for starting'. Attach the label onto the equipment where the user will be able to refer to it

8. Standard Starting Procedure

Always take great care when operating your spring starter. Once the 'Spring Starting for the First Time' procedure has been followed, this standard procedure can be followed. The operator should have access to the quick reference operator's label as a reminder of this procedure in day-to-day use:

- a. Follow points **a-k** of the first-time starting procedure, using advised number of winds for starting as previously marked on quick ref. instructions
- b. It is possible the engine does not start due to difference in climate or increased load at start-up. If this is the case, always allow the engine to come to a complete rest before retrying. Then increase number of wind rotations incrementally from the advised number of winds for each subsequent start attempt. As a general rule, a warm engine will start with white springs showing through the inspection window and a cold engine could need winding to the red springs. Winding more than is necessary to start the engine will decrease the life of the springs. Never attempt to wind beyond the point when red springs show through the inspection window
- c. In cold weather (below 0°C) it may also be necessary to use a form of cold starting aid. **ONLY USE THE ENGINE MANUFACTURER'S RECOMMENDED/APPROVED COLD STARTING SYSTEM**
- d. Once the engine has started, leave the trip lever in the **TRIPPED** position until the engine has stopped rotating and only **RESET** when the engine needs to be restarted by the spring starter

WARNING



Never operate the starter when not correctly installed on an engine

9. Unwinding the Spring Starter

It is possible to unwind the starter, should the need occur, by turning the handle **ANTI-CLOCKWISE** until the pinion has retracted and green springs are visible through the inspection window. Additional force will be required to overcome the initial friction

WARNING



Always make sure the green springs are visible through the inspection window before removing the spring starter from the engine

10. E-Pack Installation Instructions

(Applicable to E- suffixed models only)

WARNING

Failure to install the spring starter correctly will invalidate the warranty

Kineteco recommend a spring starter fitted with our 'E-Pack' system, if intended for use in a dual starter installation, where the second starter is electric. This is only possible with engines featuring a flywheel housing with two starter pockets, and is a good option as backup if the electric starter option fails.

In this type of installation, the two starters should never be operated at the same time as this can cause damage to both starters and the engine itself. To ensure this is prevented Kineteco have introduced a unique 'E-Pack' safety system in which the electric starter is disabled if the spring starter is primed for use. Spring starters featuring an 'E-Pack' will have an 'E' suffix on the model number. This guide will show you how to install and check the functionality of this safety feature.

Your E-Pack spring starter will come fitted with a 3-core cable: green/yellow, blue and brown. The integrated switch should be used to interrupt the electric starter solenoid or starter switch power.

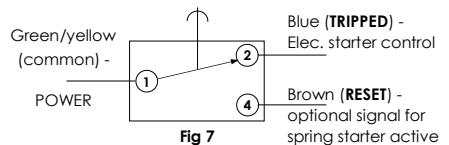

Circuit connections should be made as follows:

- With the spring starter in the **TRIPPED** position: ① - ② (electric starter solenoid/switch power active (state depicted in Fig 7))
- With the spring starter in the **RESET** position: ① - ④ (electric starter solenoid/switch power deactivated, can be used to indicate spring starter is in use, e.g., warning lamp)

NOTE: The integrated switch has a maximum 5A rating for 0-15VDC applications, so should be used in conjunction with a relay if it is likely to see a load higher than this.

Once both the electric and spring starters have been installed and the wiring completed as instructed above, carry out the following test procedure:

- a. Make sure the spring starter is unwound so that the pinion is disengaged
- b. Position the lever into the **RESET** position, **DO NOT** wind the starter
- c. Attempt to start the engine with the electric starter. The electric starter should **NOT** function
- d. Move the lever into the **TRIPPED** position and test the electric starter again. The electric starter should run meaning the E-Pack circuit is functioning correctly. If not, check all wiring and re-run through test procedure

11. General Troubleshooting

If the engine does not start within three or four attempts, there are four possible explanations:

- a. **Engine or fuel system is not primed for mechanical starting.** Check engine set up as prescribed in the 'Operating Instructions' section of this guide. The engine must be purely mechanical, or a bypass in place for any ECU controlled fuel cut-out, for total black-start functionality.
- b. **Incorrect method of starting.** The throttle should be set between three quarters and fully open and the excess fuel device, if fitted, set to the excess fuel position. Make sure the fuel is 'up' and there is sufficient fuel in the tank. On cold engines, the starter will need to be wound further than when the engine is warm to start.
- c. **Incorrect application.** The engine may exceed the maximum capacity of the spring starter or may have ancillary equipment which could cause excessive drag. Contact Kineteco if you believe this to be the case so that an alternative spring starter can be offered.
- d. **The spring starter may be faulty.** If you believe the spring starter is in need of repair, please contact Kineteco. Our trained technical staff will be able to diagnose any problem and advise on the best course of action.



WARNING

Never attempt to dismantle a spring starter yourself

This process requires specialised tooling and experience

Always contact your local Kineteco distributor to arrange repair

WARRANTY TERMS

Kineteco International Ltd provides warranty repair for 12 months from the date of despatch. At our discretion, this may include complete replacement of the returned unit. Warranty repair is subject to examination of the returned unit.

In the first instance, the end user should contact Kineteco with the serial and model number of the failed unit, and details of the nature of the failure including photographic evidence if possible.

Depending upon the nature of the problem, Kineteco may arrange local repair and issue replacement parts to allow this.

Alternatively, Kineteco may recommend that the unit be returned to either a local service agent, the original supplier or direct to the manufacturer, as appropriate. The unit will be inspected to confirm the nature of the fault in order that warranty repair can be authorised.

In the event that urgent rectification is required, Kineteco may, at our discretion, provide an immediate replacement unit against the end user's undertaking to return the faulty starter for warranty inspection. In this case the replacement starter would be invoiced at current price plus carriage, with the invoice (or a reasonable amount in the case of a disputed claim) to be credited once the faulty starter has been received and warranty failure accepted.

In the case of a valid claim, Kineteco will pay the return carriage cost (i.e., one way only).

Kineteco is keen to resolve any warranty issues at minimum cost and as quickly and easily as possible, for the benefit of all concerned. We ask users with a warranty claim to take the same approach. We sometimes find that incorrect use by the user has caused the problem leading to a warranty claim, e.g., bench testing without a load, fitting to an incorrect engine or unauthorised dismantling. We realize that such actions are accidental and may be due to unfamiliarity with our product. Given this, and that the problem has occurred during the early stages of ownership, we do our best to help the user get back under way with a minimum cost solution.

Please note that the following apply under Kineteco International's Conditions of Sale:

1. If the goods prove on inspection to be defective in material or workmanship Kineteco International undertakes at its option to rectify the problem, replace the same or refund to the Buyer the price of the goods and in no circumstances will liability exceed the cost or replacement of the price paid by the buyer for the goods.
2. The liability of the Seller shall only apply to defects that appear under proper use and under conditions of operation not more onerous than those declared to Kineteco International and in particular, shall not apply to defects which arise from the Buyer's neglect, misuse or from normal wear and tear.
3. Any goods returned to the Kineteco International and replaced by them shall be the property of Kineteco International.
4. The Seller's liability under this clause shall be in lieu of any warranty or condition implied by law as to the quality or fitness for any particular purpose of the goods and save as provided in this clause, the Seller shall not be under any liability, whether in contract tort or otherwise, in respect of defect or injury.
5. Complaints by the Buyer in respect of the goods alleged to be defective shall be made within one year from sale of goods and shall not entitle the Buyer to withhold or set off payments due to the Seller.

Whilst every care has been taken in compiling this publication, Kineteco International Ltd cannot accept responsibility for any inaccuracies. Kineteco International Ltd has an ongoing programme of design and development which may well alter product specifications. Kineteco International Ltd reserve the right to alter specifications without notice and whenever necessary to ensure optimum performance from its product range.

ALL RIGHTS RESERVED

No part of this publication may be reproduced, stored in a retrieval system, or transmitted in any form or by any means, electronic, mechanical, photocopying, recording or otherwise, without the prior written permission of Kineteco International Ltd.

This page is left intentionally blank

Card Gauge

(Cut along
dashed lines)

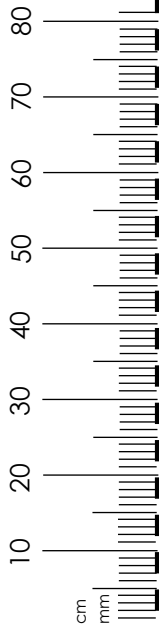
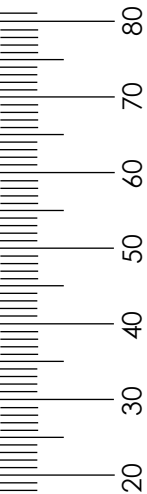

Version 2
(Updated 27-01-2016)

Kineteco International Ltd.,
Unit 10, Willesborough Industrial Park,
Ashford, Kent TN24 0TD UK

Tel: +44 (0)1233 811500

Website: www.springstarter.com

Email: technical@springstarter.com

Part No. 96289